

Walk-behind floor saws Ø 450 & 500 mm

Our extensive range of floor saws includes productive saws for floors, driveways, car parks, roadways, runways, new concrete, old concrete and asphalt. The blades and machines must safely and powerfully work together with the material being cut.

In addition to prioritizing the requirements of the users, we evaluate the capacity and efficiency of our equipment, allowing us to continually develop efficient solutions.

These floor saws are available with either gasoline or diesel engines.



Ø 400, 450 & 500 mm



EN13236



POWERED by **HONDA**
norm SAE J1349



FEATURES AND BENEFITS

- Spring loaded base plate pivot system.
- Poly-V belts for optimum power transmission.
- PACLITE floor saws are robust, well designed and easy to use thanks to features as protective cage, lift bail and cutting depth indicator.
- Raise/lower assist system, using springs.
- Engine and bladeshaft mounting system reduce vibrations and give better cutting performance.
- Bladeshaft system allows for a minimum of 250 maintenance-free hours and eliminates daily greasing of bearings.
- Spring-assist screw feed adjustment reduces the force required to adjust the blade in and out of the cut.
- Electronic hour meter.
- Integrated document and tool box.
- Front drive axle mounted with four bearings.

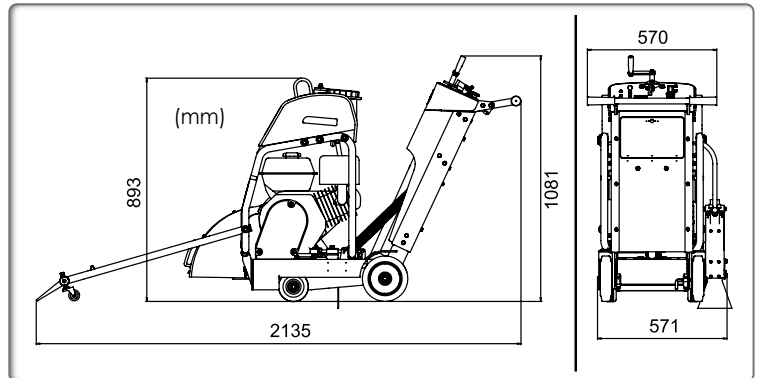

	Code	301.40.10000	301.41.10001B40
	Model	PRECISION CUT 4-5	PRECISION CUT 500D
Dimensions L x W x H (mm)		2135 x 571 x 1081	2135 x 571 x 1081
Weight (kg)		179	199
Max cutting depth (mm)		146-164-192	146-164-192
Blade size (mm)		400-450-500	400-450-500
Blade speed (m/s ²)		57,6	57,6
Water tank capacity (l)		37	37
Engine		Honda GX390	Hatz Diesel 1B40
Net power hp (kW)		11,7 (8,7)	11 (7,5)
Rated engine speed (rpm)		3600	3600
Fuel tank capacity (L)		6,1	
Engine oil capacity (L)		1,1	
	(L/h - rpm)	3,5 - 3600	
		Certified power SAE J 1349	



Advanced control panel with hour meter



Document and tool box



Compact design