

Correcting a concrete floor

PACLITE CUB grinder is small floor grinder developed for correcting and rectifying any concrete surface. This machine is equipped with a powerful single-phase electric motor.

The removable diamond tool set is easy to access and replace.

The folding handle makes the machine compact and easy to transport.

FEATURES AND BENEFITS

- Tool set easy to change.
- Powerful electric motor.
- Adjustable handle.
- Outlet for connecting a dust extractor for indoor work.
- One set of diamond segments included in the machine.

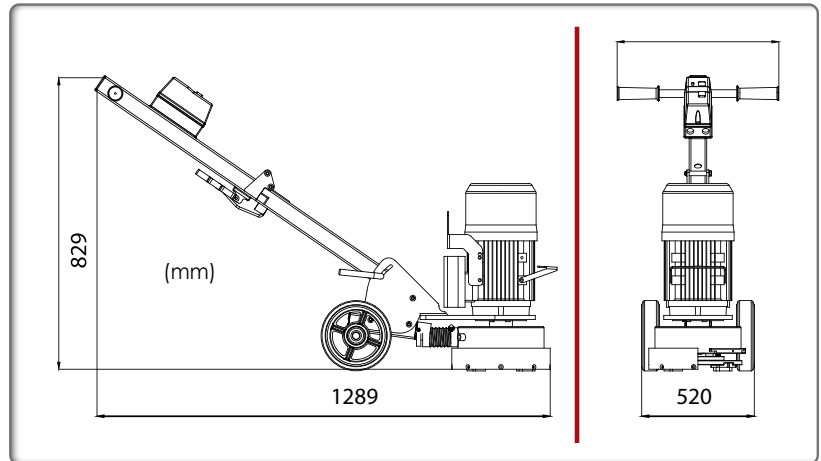

Code	CGS250-040500	BLS-HHC	BLS-SC
Option	1 Set of 5 diamond segments	For reinforced concrete SUPER HARD	Fresh concrete/abrasive

Code	PSG-SEA
Model	Cub Grinder
Working diameter (mm)	230
Segments	5
Dimensions (folded) L x W x H (mm)	800 x 460 x 700
Packing size (mm)	800 x 500 x 820
Net weight (kg)	53
Engine speed (rpm)	1430
Power source electric engine	220~240 V at 2,2 kW (3 hp) 50 Hz



Standard segments concrete



Diamond segments easy to change, without any tools needed



Option: set of four diamond segments

